



Evergreen Global Group Profile

艾为格伦集团简介



March 8th, 2025



Company Overview

公司概况



Evergreen Global Group was founded in Year 2003 in Ningbo, China and has established 9 factories. From 2004 to 2023, we established 6 factories in China. In 2025, we have established 3 factories in Thailand, the Philippines, and Vietnam, and expect to start production in the second half of 2025. For over twenty years, Evergreen Global Group has been specializing in providing auto parts, robot parts and mechanical components to North American companies by manufacturing in IATF:16949, AS9100 and NADCAP certified facilities in Asia. With many years' of operating experience in both China and the U.S, we have a proven record providing Quality and On-time delivery. Evergreen Global Group's strong manufacturing, engineering and financialties, coupled with an expansive network of relationships and strength in logistics on both ends ensures our customers significant value and increased profits.

Our expertise: Manufacturing of mechanical components in the automotive, robot and aerospace industries.

Our Performance: Tier 1 or Tier 2 Supplier of Ford, GM, Volvo, Toyota, Tesla, Etc.

艾为格伦集团于2003年在中国宁波成立，目前已建立9家工厂。从2004年到2023年，我们在中国建立了6家工厂。2025年，我们在泰国、菲律宾和越南建立了3家工厂，预计将于2025年下半年开始生产。二十多年来，艾为格伦集团一直专注于通过在亚洲IATF:16949、AS9100和NADCAP认证的工厂生产，为北美公司提供汽车零部件、机器人零件和机械部件。凭借在中国和美国多年的运营经验，我们在提供质量和准时交货方面有着良好的记录。艾为格伦集团强大的制造、工程和财务实力，加上广泛的关系网络和两端物流实力，确保了我们的客户获得巨大的价值并增加了利润。

我们的专长：汽车、机器人和航空航天工业的机械零件制造。

我们的业绩：一级或二级供应商，包括福特、通用、沃尔沃、丰田、特斯拉等。



Key Data

主要信息



Company 公司名称	Evergreen Global Group 艾为格伦集团
Ownership 公司性质	Private owned 私营
Location 公司地址	Ningbo, P.R. China 中国宁波市
Founded 注册时间	Founded in Year 2003 in Ningbo 2003年在宁波成立
Main Parts 主要产品	汽车配件、机器人配件和航空配件如压铸件、锻造件、精铸件、精密加工件。Auto parts, robot and aerospace parts, such as Die casting, Forging, Precision castings and Machining parts.
Turnover 销售额	328 million USD in year 2024 2024年销售额为3.28亿美元
Production Area 生产面积	126,200 M ²
Quality System 质量体系	IATF 16949, ISO9001, etc
Staff 员工人数	2168



Company Development History

公司发展历程-1

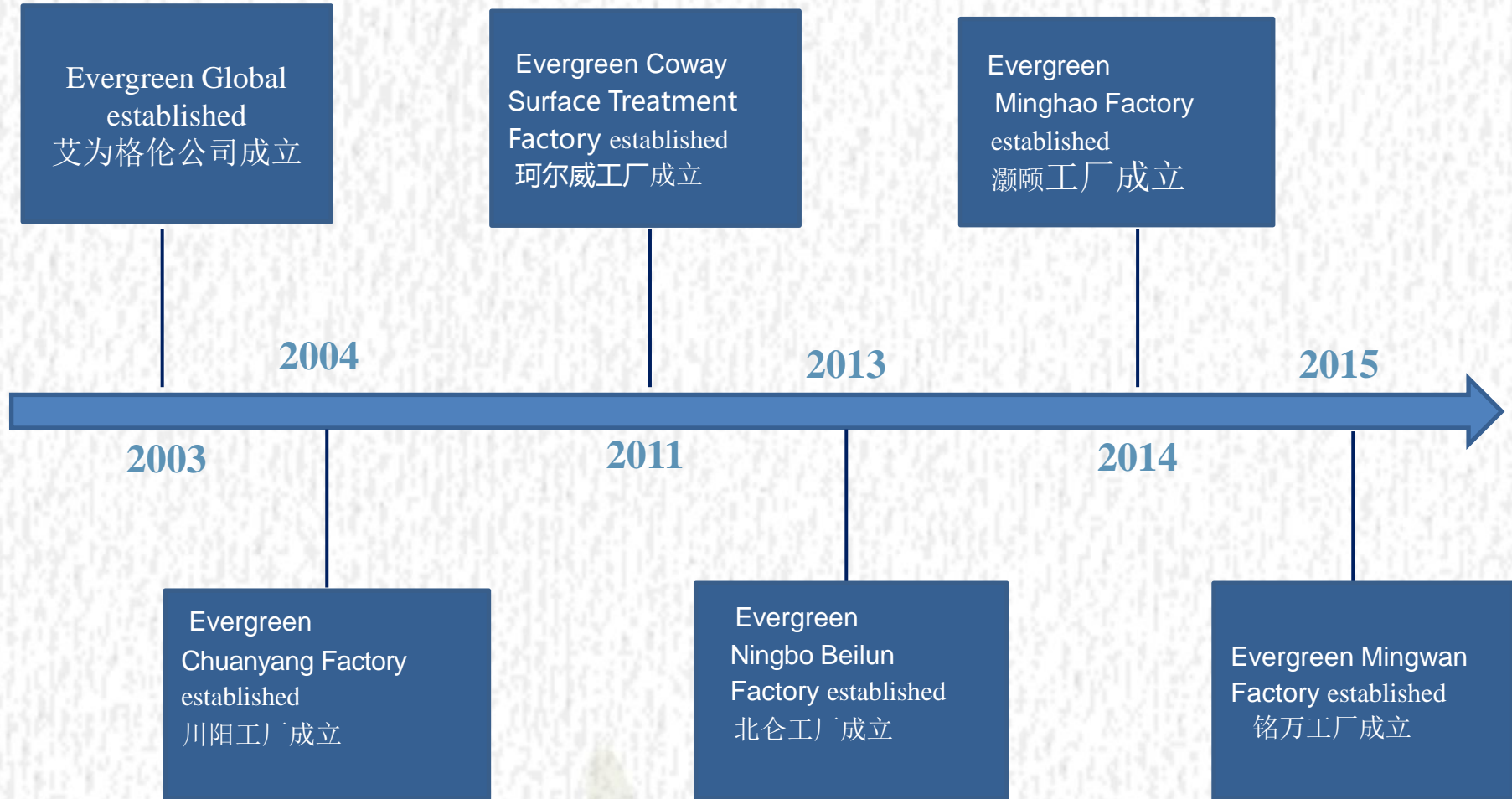



Company Development History

公司发展历程-2

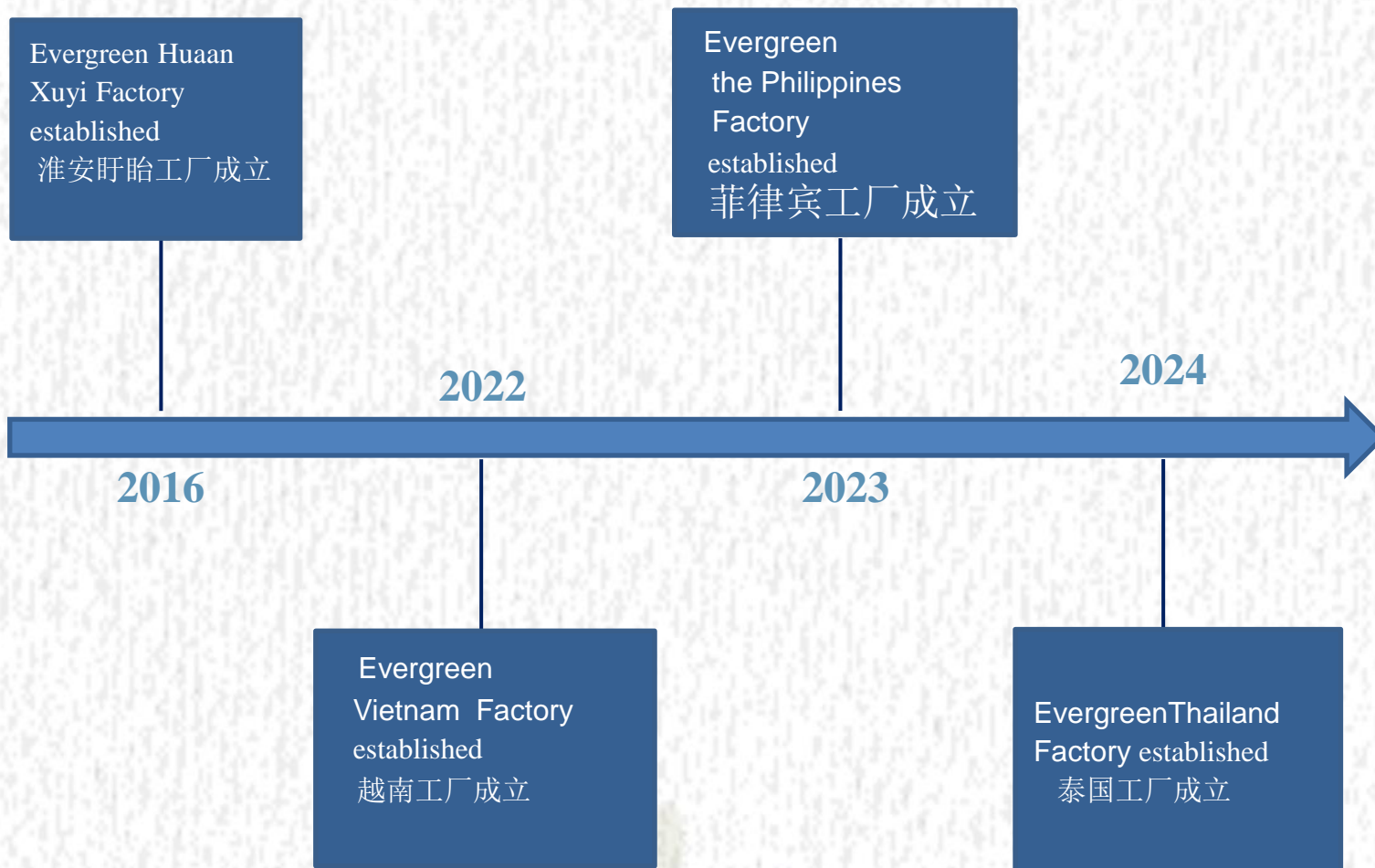



Company Headquarters Chart

公司总部组织架构图

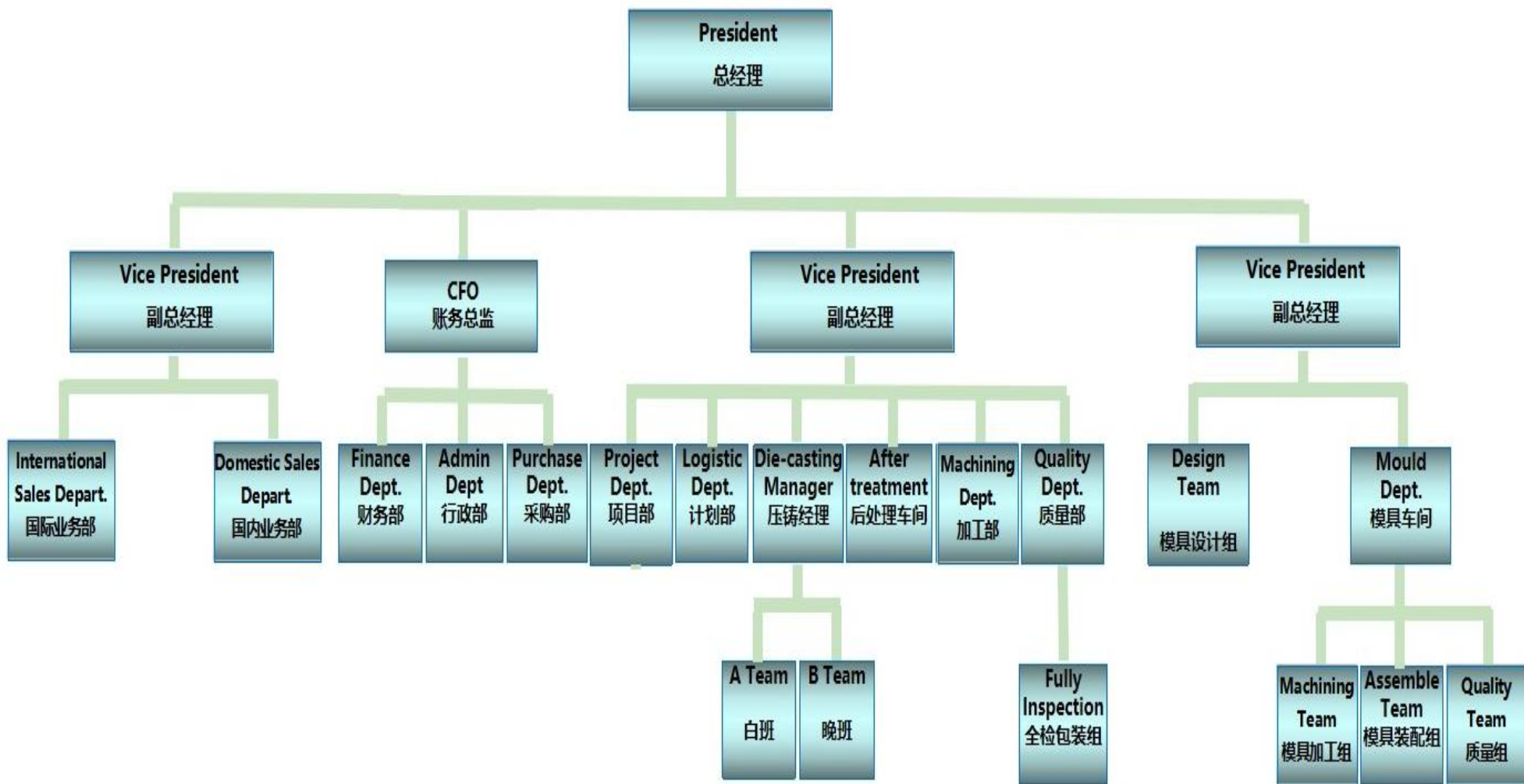



Company Picture

公司照片





Main Products 主要产品-1

Rough Die-casting Parts





Main Products 主要产品-1

Powder Coating Parts





Main Products 主要产品-2

Forging Parts 锻造零件





Main Products 主要产品-3

Precision Steel Pipe 精密钢管

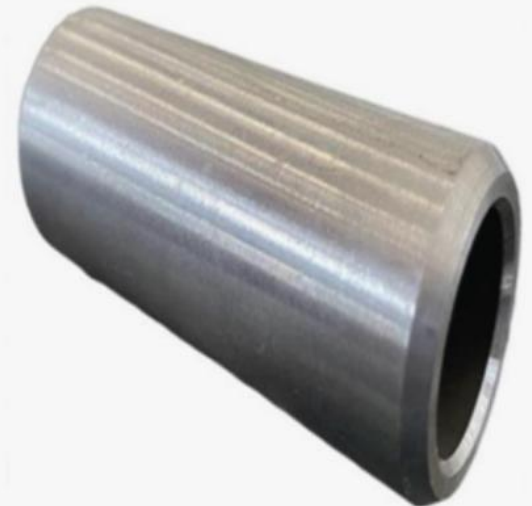
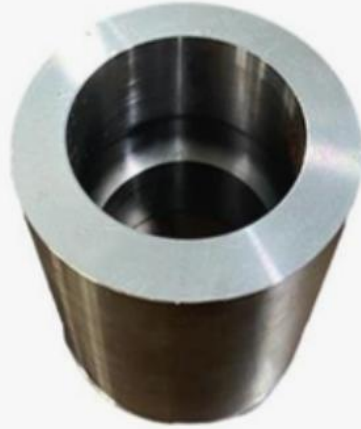



Main Products 主要产品-4

Sand Casting Parts 砂铸件





Main Products 主要产品-5

Fine Machining Parts 精加工件

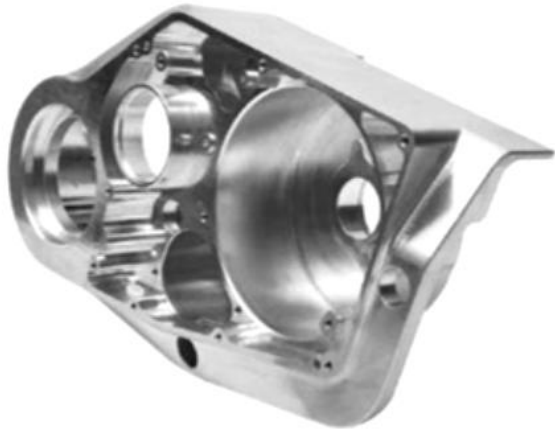



Main Products 主要产品-6

Cold Heading Parts 冷镦件





Main Products 主要产品-7



Aerospace Parts 航空零件

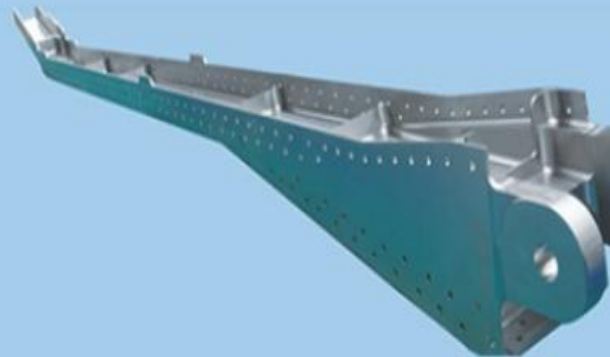
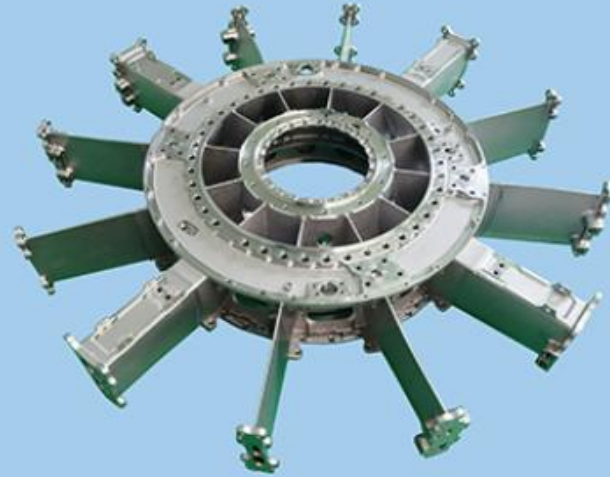
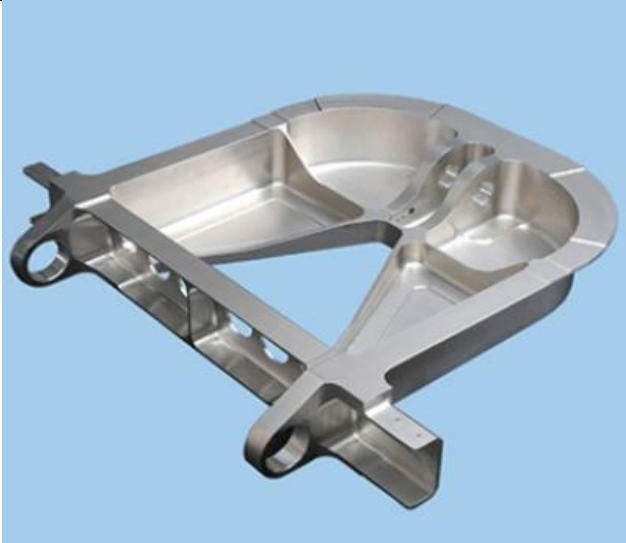



Main Products 主要产品-8



Aerospace Components 航空配件

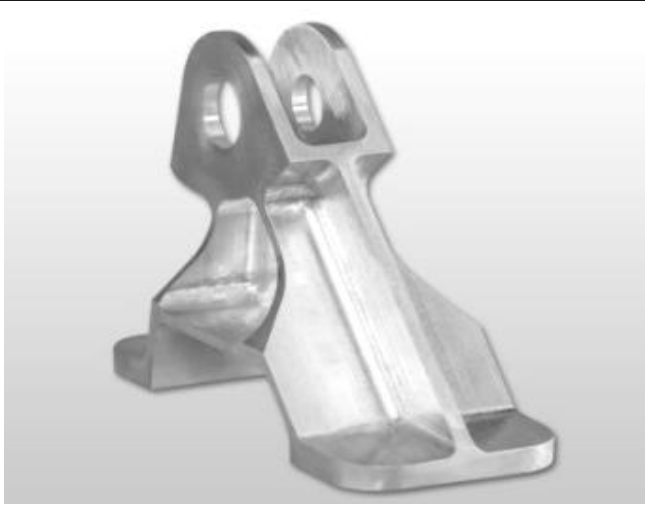



Main Products 主要产品-9



Robot Parts 机器人配件

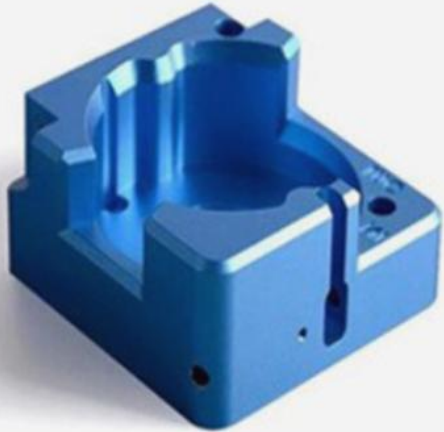



Die-casting Workshop 压铸车间-1

Equipment List 设备清单



Total: 9

Description名称	Brand品牌	Quantity
Centralized melting furnace熔化炉	Zhengying	1
Secondary furnace二次炉	Liangshi	1
180T HP die-casting machine 压铸机	Yizumi	1
300T HP die-casting machine 压铸机	Yizumi	1
500T HP die-casting machine 压铸机	Yizumi	2
650T HP die-casting machine 压铸机	Yizumi	1
800T HP die-casting machine 压铸机	Yizumi	1
1250T HP die-casting machine 压铸机	Yizumi	1



Die-casting Workshop 压铸车间 -1



Overview:





Forging Workshop 锻造车间-2

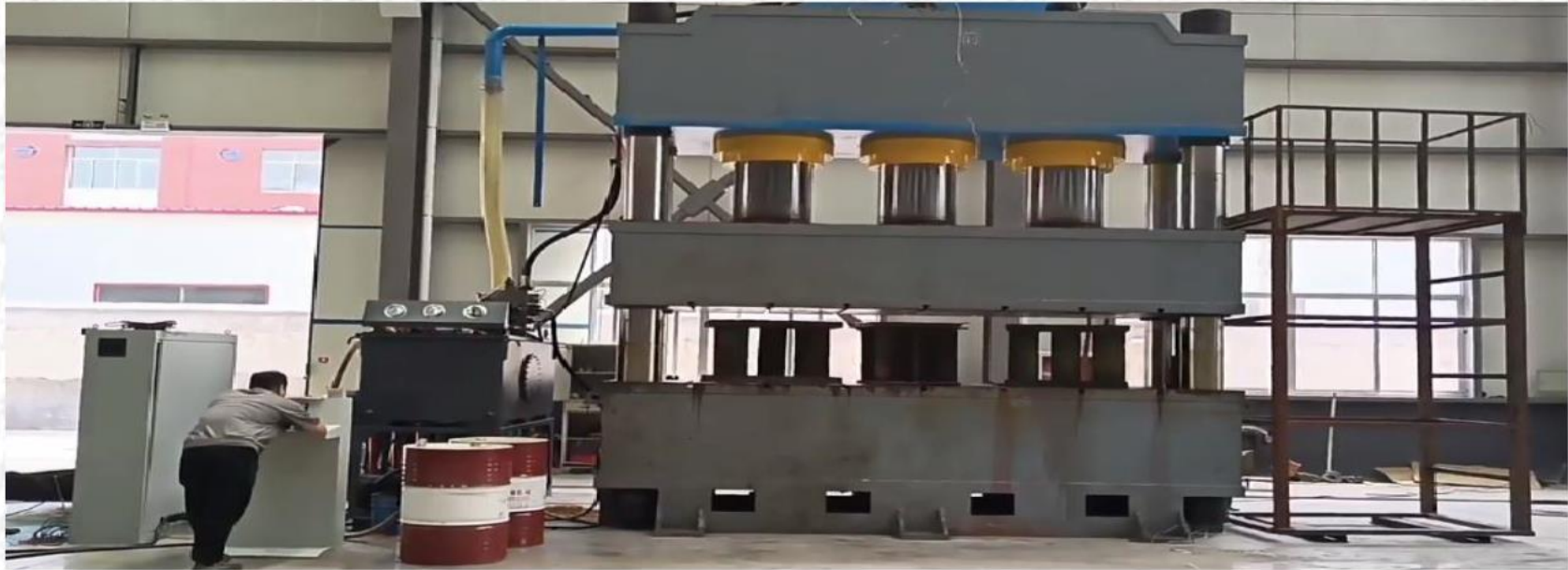



Precision Steel Pipe Workshop



精密钢管车间 -3





Sand Casting Workshop 砂铸车间-4



Overview:





CNC Machining Center 加工中心-5

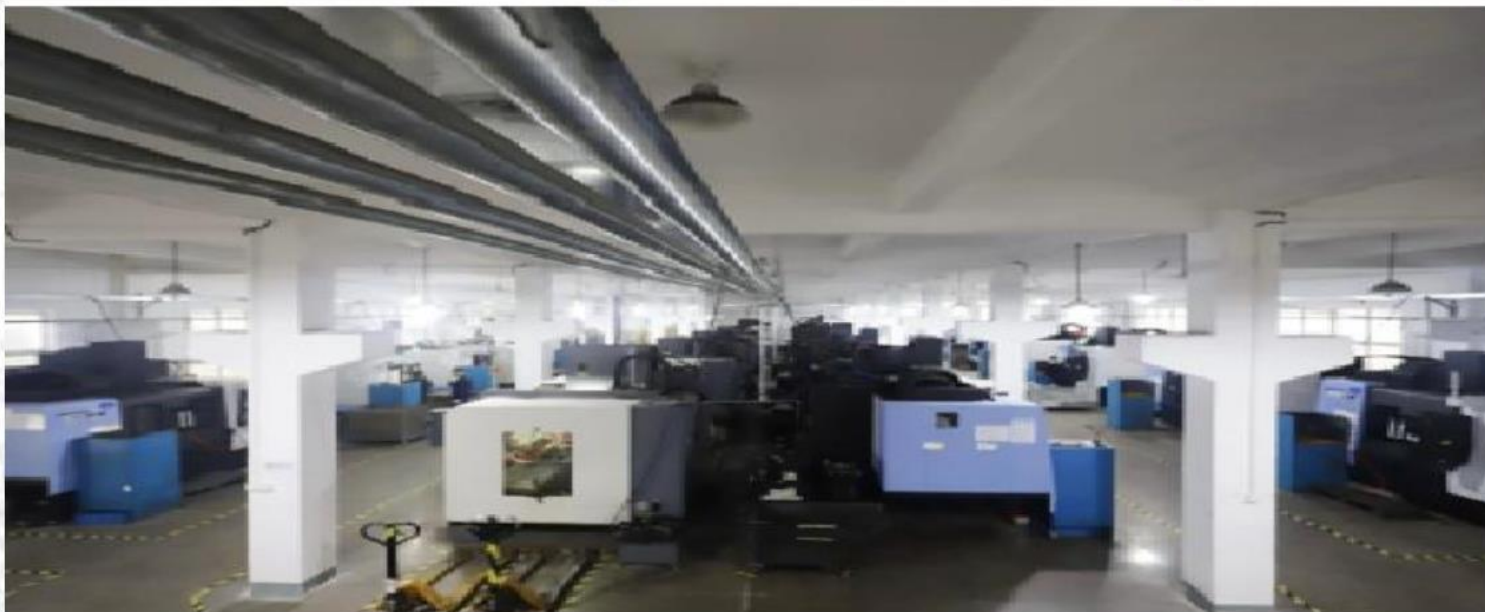



Cold Heading Workshop 冷镦车间-6



Overview:



Surface Treatment Workshop



表面处理车间-7



Electrophoresis workshop 电泳车间



Powder coating workshop 喷塑车间

Investment Casting Workshop



熔模铸造车间-8



脱蜡釜
Dewax Kettle



抛丸机
Shot Blasting



压力机
Punching Machine



激光压铆机
Laser Riveter





Tooling Workshop 模具车间-9

Equipment List 设备清单

Total: 17

Description(名称)	Brand (品牌)	Originate (原产国)	Quantity (数量)
CNC Milling Center铣削中心	Yongjin	China中国	5
CNC Lathe车床	Yongjin	China中国	1
EDM电火花	Ou milong	China中国	3
Drilling钻孔攻丝	zhongjie	China中国	2
Grinding研磨	jiande	Taiwan,China中国台湾	1
High-speed wire cutting 高速线材切割	GF	China中国	2
Medium-speed wire cutting 中速线材切割	GF	China中国	1
Spotting machine点胶机	Kangxin	China中国	2



Tooling Workshop 模具车间 -9

Overview:

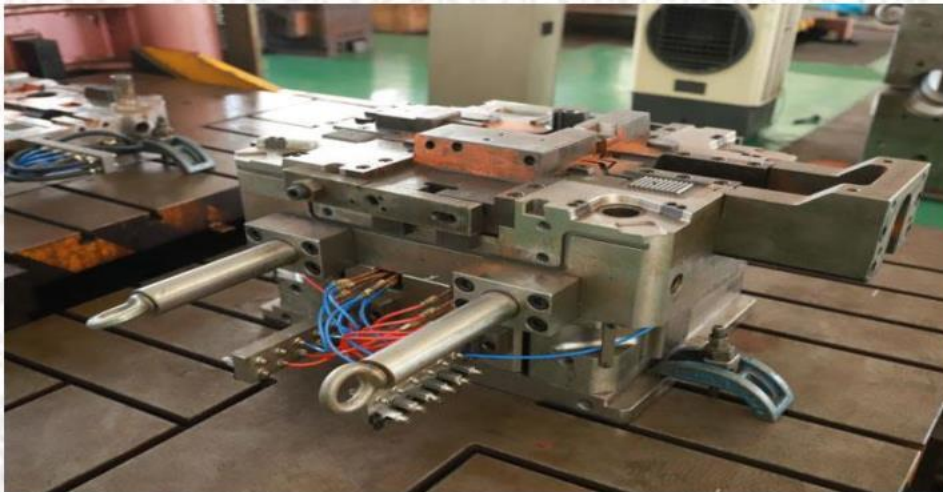



Tooling Research and Development



模具设计和开发

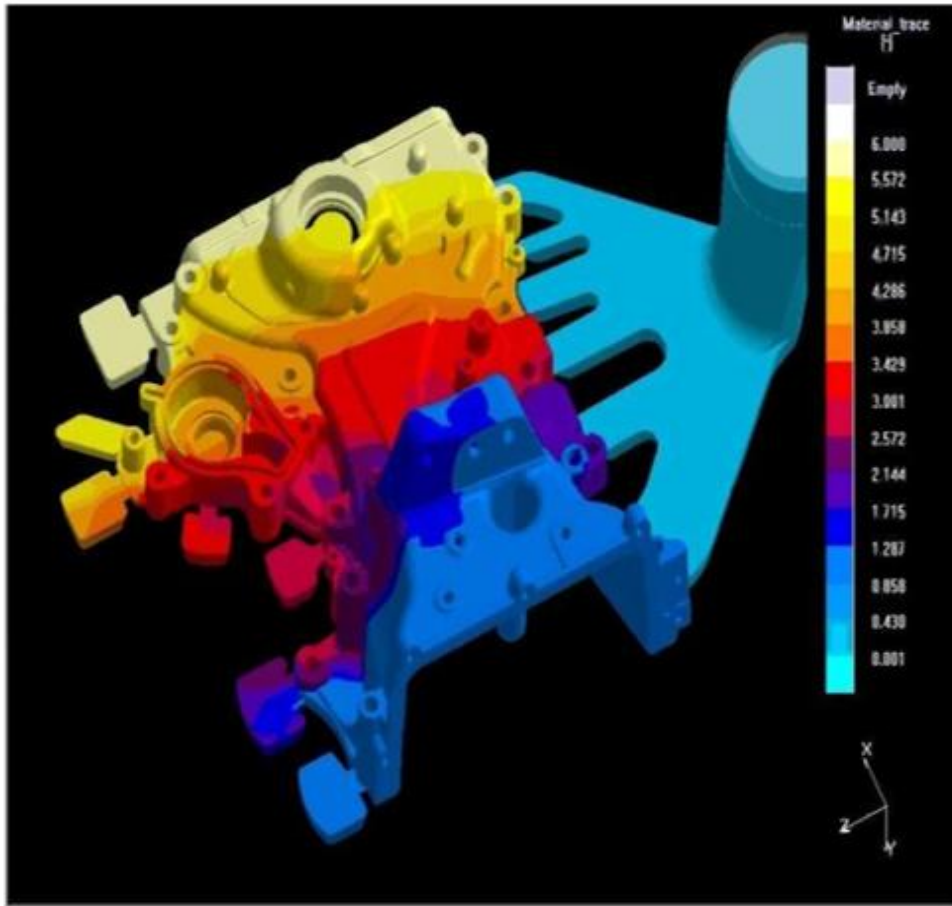

模流分析
Mold flow Simulating

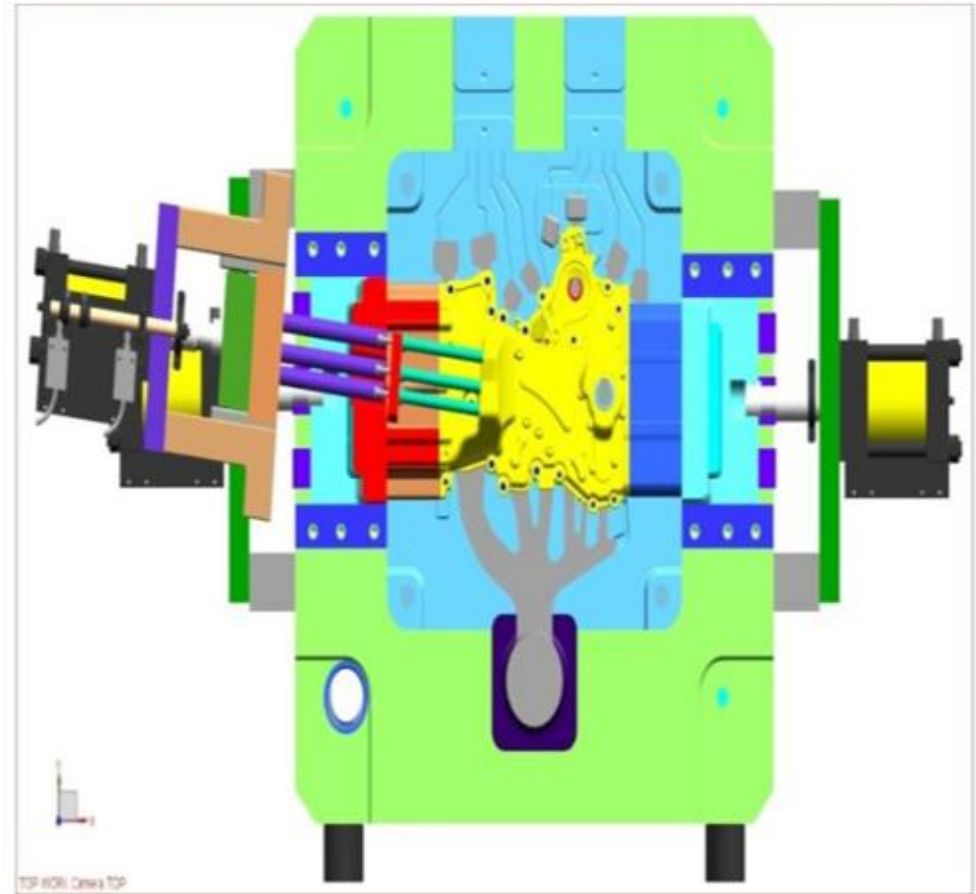

模具方案
Mold Design



Test Equipment Show 测试设备展示



Spectrometer
光谱分析仪

X-Ray
探伤仪

CMM
三坐标

Tensile Tester
拉力试验机

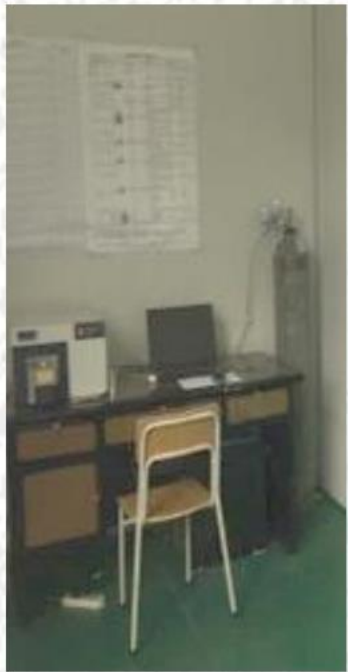



Quality System Certificate

质量体系认证

IATF 16949 Certificate 认证-1



Certificate of Registration

This certificate has been awarded to

Evergreen (Ningbo Beilun) Machinery Co., Ltd.

No.1-2, Building 1, No.310, Chunxiaolehai Road, Beilun District, Ningbo City,
Zhejiang Province, China
USI Number GHWARG

in recognition of the organization's Quality Management System which complies with

IATF 16949:2016

The scope of activities covered by this certificate is defined below

Please refer to the Appendix

Certificate Number: 128500/1/0001/SM/En			
Date of Issue of Certification Cycle	Issue Number	Certificate Expiry Date	Certification Cycle
17 January 2025	1	16 January 2028	1
Revision Date	Revision Number	Original Certificate Issue Date	Scheme Number
17 January 2025	0	17 January 2025	0562709

For detailed explanation for the data fields above, refer to <http://www.urs-holdings.com/logos-and-regulations>

Issued by

Mukesh Singhal - On behalf of the Schemes Manager





Quality System Certificate

质量体系认证

IATF 16949 Certificate 认证-2



Certificate of Registration

This certificate has been awarded to

Ningbo Evergreen Haoyi Machinery Co., Ltd.

Majiadu Bridge, Danshui Fishery Village, Yunlong Town, Yinzhou District, Ningbo City, Zhejiang Province, China
USI Number YZAMSM

In recognition of the organization's Quality Management System which complies with

IATF 16949:2016

The scope of activities covered by this certificate is defined below

Manufacture of Metal Machined Parts (Excludes Product Design under Clause 8.3)

Certificate Number **131774/A/0001/SM/En**

A certificate number of 0001, meaning the Client has a single site Certified. If the client has three Offices in Main site included in the Certificate with URS, Certificate number of 0001, or greater (e.g. 0001/0001/01/01) when the above details have been also certified with URS, or such, the following comments shall apply: "The validity of this certificate depends on the validity of the main certificate"

Date of Issue Certification Cycle	Issue Number	Certificate Expiry Date	Certification Cycle
29 October 2024	1	28 October 2027	1
Revision Date,	Revision Number	Original Certificate Issue Date	Scheme Number
29 October 2024	0	29 October 2024	0552579

For detailed explanation for the data fields above, refer to <http://www.urs-holdings.com/logos-and-regulations>

Issued by



Mukesh Singhal - On behalf of the Schemes Manager





Quality System Certificate

质量体系认证

IATF 16949 Certificate 认证-3



Certificate of Registration

This certificate has been awarded to

Ningbo Yinzhou Hengxi Mingwan Evergreen Fastener Factory

(300 Meters South of the Fengqian Line) Qian'ao Industrial Zone, Hengxi Village,
Hengxi Town, Yinzhou District, Ningbo City, Zhejiang Province, China

In recognition of the organization's Quality Management System which complies with

IATF 16949:2016

The scope of activities covered by this certificate is defined below

**Manufacture of Forging Parts (Excludes Product Design under Clause 8.3)
- [USI YW4WYM]**

Certificate Number 128589/A/0001/SM/En			
Date of Issue of Certification Cycle	Issue Number	Certificate Expiry Date	Certification Cycle
26 October 2023	1	25 October 2026	1
Revision Date	Revision Number	Original Certificate Issue Date	Scheme Number
26 October 2023	0	26 October 2023	0486381

For detailed explanation for the data fields above, refer to <http://www.urs-holdings.com/logos-and-regulations>

Issued by



Mukesh Singhal - On behalf of the Schemes Manager





Quality System Certificate

质量体系认证

IATF 16949 Certificate 认证-4



Certificate of Registration

This certificate has been awarded to

Zhejiang Chuanyang Evergreen Metal Products Co., Ltd.

Floor 1-3, North Building, No.9 Qinwu Road, Zhongcun Industrial Park, Diankou Town, Zhuji City, Shaoxing City, Zhejiang Province, China
USI Number GR2GYX

in recognition of the organization's Quality Management System which complies with

IATF 16949:2016

The scope of activities covered by this certificate is defined below

Manufacture of Multi-station Cold Heading Metal Parts and Metal Machining Accessories (Excludes Product Design under Clause 8.3)

Certificate Number 136954/A/0001/SM/En

A certificate number of URS, confirms the Client has a single site Certified & the date their Issue Date or their site is unique to the Certified scope with URS. A certificate number of 0001 or greater (e.g., www.urscertification.com) refers to a client that has more than one site certified with URS, as such, the following statement shall apply: "The validity of this certificate depends on the validity of the main certificate"

Date of Issue of Certification Cycle	Issue Number	Certificate Expiry Date	Certification Cycle
26 December 2024	1	25 December 2027	1
Revision Date	Revision Number	Original Certificate Issue Date	Scheme Number
26 December 2024	0	26 December 2024	0560344

For detailed explanation for the data fields above, refer to <http://www.urs-holdings.com/logos-and-regulations>

Issued by



Mukesh Singhal - On behalf of the Schemes Manager





Quality System Certificate

质量体系认证

IATF 16949 Certificate 认证-5



Bureau Veritas Certification

Certificate of Approval

AWARDED TO

NINGBO COWAY SURFACE TREATMENT TECHNOLOGY CO. LTD.

2# Building, No.18 Nanhai Road, Xinqi Street, BeiLun District, Ningbo City, Zhejiang Province, 315800, China

Bureau Veritas Certification certify that the Quality Management System of the above organisation has been audited and found to be in accordance with the requirements of

IATF 16949 - FIRST EDITION

and the applicable customer specific requirements



SCOPE

Manufacturing

PERMITTED EXCLUSION(S)

8.3 - Design and development of products and services

PRODUCT(S) DELIVERED

spray and electrophoresis

Date Of Certification: 18-07-2023

Date Of Expiration: 17-07-2026

IATF Certificate N°: 0479038

Bureau Veritas Certification Certificate No: CN045308 - IATF

Revision: 1



For Bureau Veritas Certification Holding, Le Triangle de l'Arche, 8 Cours du Triangle - 92800 Puteaux - France
(The official document is in English. Any translations of this document shall be used for reference only.)



Quality System Certificate

质量体系认证

ISO9001 Certificate 认证-6





QUALITY MANAGEMENT SYSTEM CERTIFICATE

Registration no.: 41323Q00653R05

Hereby certify

Evergreen (Ningbo Beilun) Machinery Co., Ltd.

Unified social credit code: 91330206MAC8RUNKSU

Address: No.1-2, Building 1, No. 310 Chunxiaolehai Road, Beilun District, Ningbo City,
Zhejiang Province(315810)

Quality management system in line with

GB/T19001-2016/ISO9001:2015

Certification coverage

Machining of precision machinery parts; Manufacturing of aluminum die-castings.
Code: 17

The certificate shall be subject to supervision and verification within 12 months of each period of validity and shall be used in conjunction with the annual confirmation certificate. This certificate information can be checked on the official website of the Certification and Accreditation Administration of the People's Republic of China (www.cca.gov.cn) and the website of our company (www.zcgjrz.com).

Certification date: May 26, 2023
Renewal Date: Jun 07, 2024
Valid until: May 25, 2026

ISO9001





Zhongci International Certification Co., Ltd.
Building 16<1-3>, Binhai Two Road 77, Hangzhou Bay New District, Ningbo, China
Website : www.zcgjrz.com Tel : 0086-574-63520088





Quality System Certificate

质量体系认证

ISO9001 Certificate 认证-7



中安认证

**QUALITY MANAGEMENT SYSTEM
CERTIFICATE OF CONFORMITY**

This is to certify that Quality Management System of

Evergreen Shunyuan Company Limited

Unified Social Credit Identifier:91330212MA2826QF3T
(Register ADD: No. 8, Building B, Gongmao Road, Hongxin Village, Gaoqiao
Town, Haishu District, Ningbo City, Zhejiang Province
(excluding carport and garage) postcode:315175)

has been found to conform to Quality Management System Standard:
GB/T 19001-2016/ISO 9001:2015

This quality management system covers following product(s):

**Manufacturing of automotive parts and production
of plastic products**

**ADD:No. 8, Building B, Gongmao Road, Hongxin Village, Gaoqiao
Town, Haishu District, Ningbo City, Zhejiang Province.**

The No. of this certificate is: 02824Q13585R0S
This certificate is valid from: Oct.28.2024 to Oct.27.2027
Date of issue:Oct.28.2024

Beijing Zhong-An Zhong-Hua Certification Center Co.,Ltd
(Former 8 • Certification Center of Quality System)
(ADD: 202, 2/F, No. 58, South of East 3rd Ring Road, Chaoyang District, Beijing 100022)

任磊



中国认可
国际互认
管理体系
MANAGEMENT SYSTEM
CNAS C02B-M



Member of Multilateral Recognition Arrangement

证书信息查询方式(The Website of inquiry certificate): <http://www.cnca.gov.cn>



Quality Objective 质量目标



Quality Objective in year 2025

- DPPM level \leq 100PPM
- On-time delivery 98%
- Customer satisfaction \geq 98%

2025年度质量目标

- 顾客PPM \leq 100 PPM
- 及时送货率 98%
- 顾客满意度 \geq 98%



Process Quality Control 过程质量控制



- ❑ All process quality control per control plan; 所有过程控制按照控制计划
- ❑ Tooling and equipment inspection regularly; 定期进行模具和设备检查
- ❑ QC perform First article inspection and in process quality control each two hours; QC执行首件检验和每2小时过程检验
- ❑ Operator do self-inspection; 操作工做自检
- ❑ Regular audits was conducted to verify compliance; 定期审核验证符合性
- ❑ CPK study for key dimensions and X-Bar control on site; 关键尺寸做CPK研究和X Bar控制图
- ❑ Do 100% inspection for some key items; 一些关键项目做100%检验



Use air gauge to do 100% inspection hole diameter after finished boring
用气孔量仪对孔径做100%检查



Key dimension by X-bar chart control
关键尺寸用X Bar控制图



Overseas Customers 海外客户

- Tier 1 or 2 for GM, Ford, Tesla, Volvo, Fiat, VW, Benz etc.

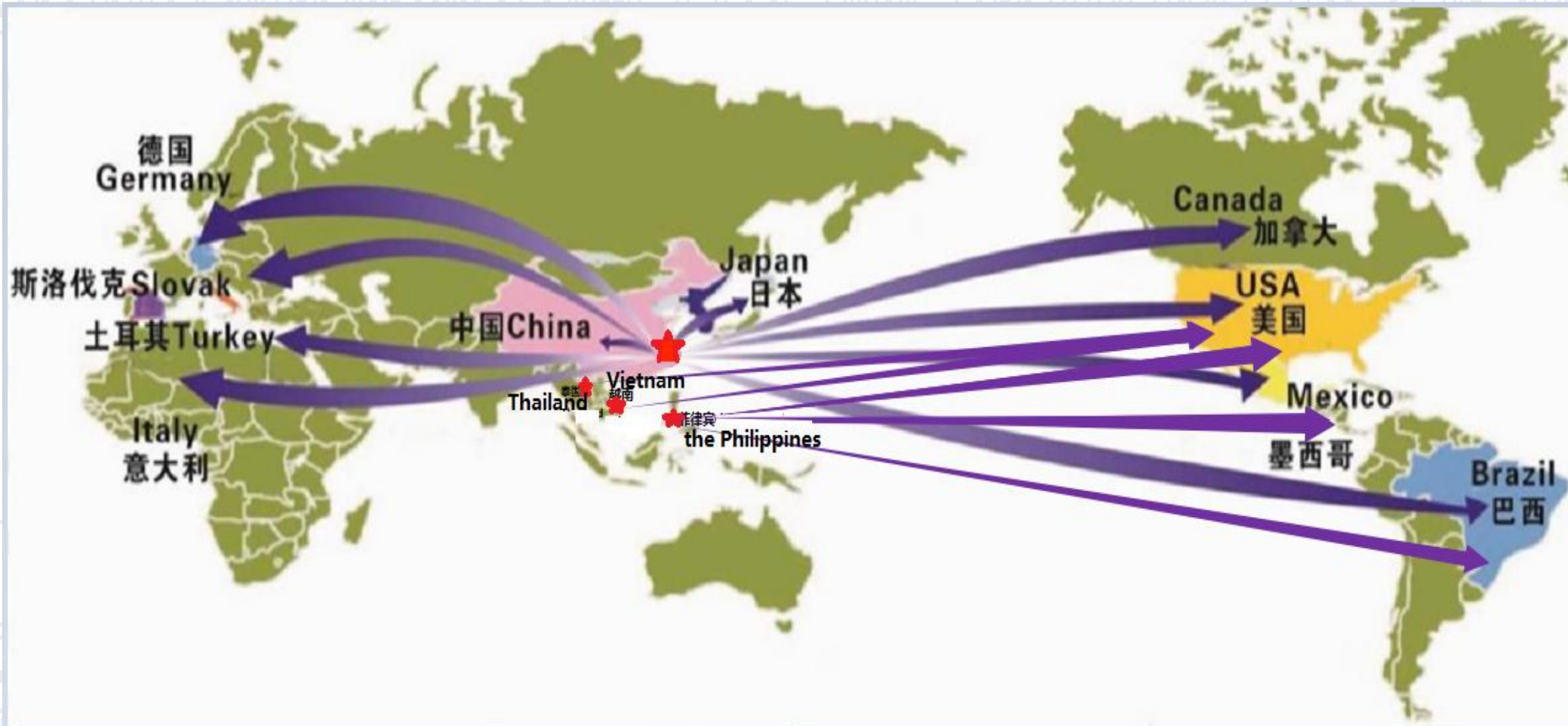



Product List of Some Customers(Partial)

部分客户产品清单



No.序号	Product Type产品类别	Main products主要产品
1	Aluminum die-casting parts 铝压铸件	HOLDER&ARM_VOLVO_Mack_ LH&RH for Volvo 左右底座和支臂供沃尔沃,
2	Aluminum die-casting parts 铝压铸件	HOLDER&ARM LH&RH UPPER&BASE BLACK for Tesla 左右后视镜支臂&底座高光黑色喷涂件供特斯拉
3	Precision steel pipe 精密钢管	Seamless steel pipe for Ford 无缝钢管供福特
4	Precision steel pipe 精密钢管	PIPE-HTR INL for GM LT2 OilFilter Adapter Asm for GM Group 过滤器适配器组件供通用集团
5	Investment Casting Parts 熔模铸造件	5th Wheel Attachment for Ford 车轮配件供福特
6	Sand casting parts 砂铸件	BLOOMFIELD C10 LARGE RUNNER for Ford 制动件供福特



Contact Us联系我们



Contact US: evergreenglobal@vip.163.com

China Phone:(86)13916257998, USA Phone:(520)3311992

U.S.A Office:

- Evergreen Global, 1401 E. 20th. Street. Tucson. AZ 85719
Phone: (520)3311992

Factories in China:

- No. 38 Lingfeng Rd, Haishu District. Ningbo City, Zhejiang Province, China ZIP 315000
Phone: (86 574)88298207
- No. 8, building B, Gongmao Road, Gaoqiao Town, Haishu District, Ningbo City, Zhejiang Province, China ZIP 315000 Phone: (86 574)87271102
- No. 310 Lehai Road, Beilun District, Ningbo City, Zhejiang Province, China ZIP 318000
Phone:(86)15299006017
- No.18, Fengyang Avenue, Xuyi Economic Development Zone, Huai'an City, Jiangsu Province, China ZIP 211700 Phone:(86)18958268398



Contact Us 联系我们



Factories in South-East Asia:

- 99 Village No. 1 Klong Prawet Ban Pho Chachoengsao 24140 Bangkok City, **Thailand**
Phone: 66-20260661
- Hiep Phuoc Industrial Zone, Long Thoi Commune - Nha Be District Ho Chi Minh City, **Vietnam**
Phone: 84-2856782506
- FPIP , Batangas, Pan - Philippine Hwy, Santo Tomas, 4234 Batangas City, **Philippines**
Phone: 63-286263081





Thank you!

谢谢您!

Evergreen Global Group

艾为格伦集团

